

Upgrade **Your Asset** and **People Management**

MWC01 Badge Repeater



MBT02 Asset Repeater



Industrial Workspaces



Office Environments



Healthcare Facilities



Warehouse Asset Tracking

MRepeater integration, MWC01 Badge Repeater and MBT02 Asset Repeater. MWC01 performs accurate personnel management, with high accuracy and emergency response abilities. Besides, MBT02 performs asset tracking with efficiency. Improve workplace efficiency and security with these 2 smart gadgets, which provide precise people management, and efficient asset monitoring, and both of them are cutting-edge hardware solutions in IoT industry.

FEATURES ▶

MWC01 Badge Repeater



- High positioning accuracy
- Vibration feedback
- Smart magnetic charging
- IP67 dust & water resistance
- Multiple RFID frequencies

MBT02 Asset Repeater



- Broadcasting & scanning supported
- Disassembly alerts reminding
- 3 years service life
- Batch device management
- Flexible deployment
- Lightweight design

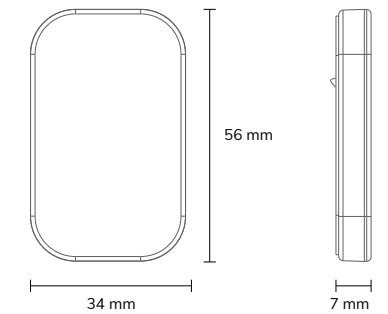
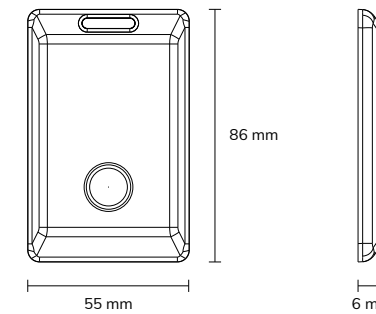

MODEL

Material
Weight
Protection
Battery
Battery Life
Sensor
Vibration Motor
LED
RFID
OTA
Configuration App

MWC01 Badge Repeater

ABS + PC
19 g
IP67
1 rechargeable battery, 290 mAh
One charge - 16 days (Active time < 8 hours)
Accelerometer
√
1 RGB light
LF/ HF/ UHF optional
Supported
MRepeater (Android supported)

MBT02 Asset Repeater

ABS
17 g
/
Coin battery, 500 mAh
3 years (default setting)
Accelerometer (optional)
/
Red
/
Supported
MRepeater (Android supported)